

SERIE KILOMETRAJES



	A
a	500
b	350
c	15
a1	150BM
b1	63
c1	120Lm
d1	236
e1	219
r	50

Serie de delineadores de peligro

D1 (I o D)

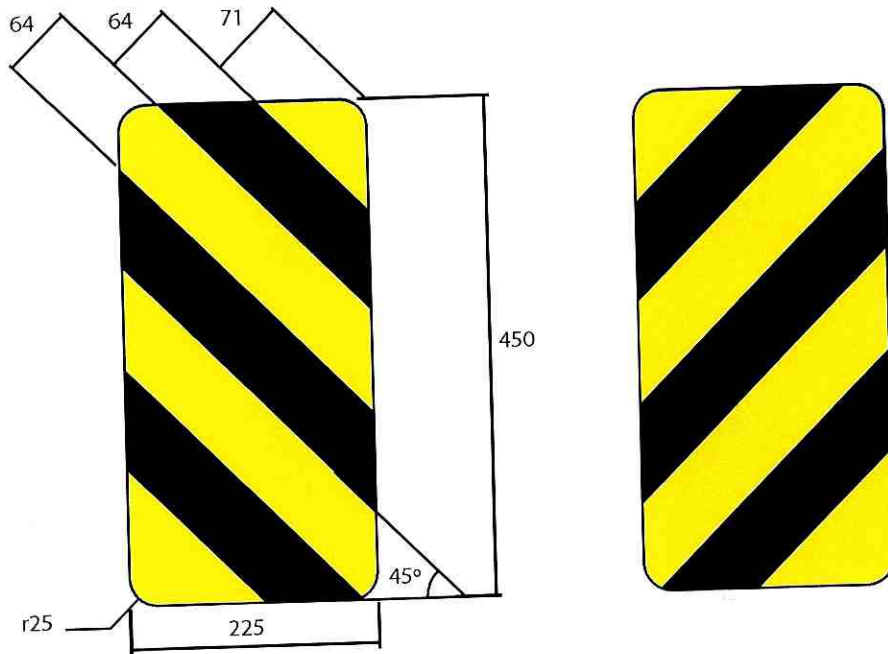

D2

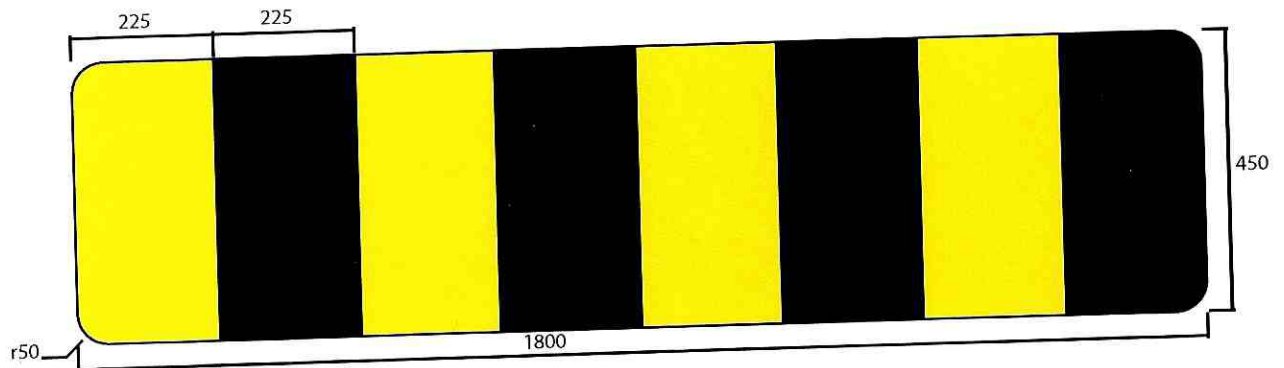

D3

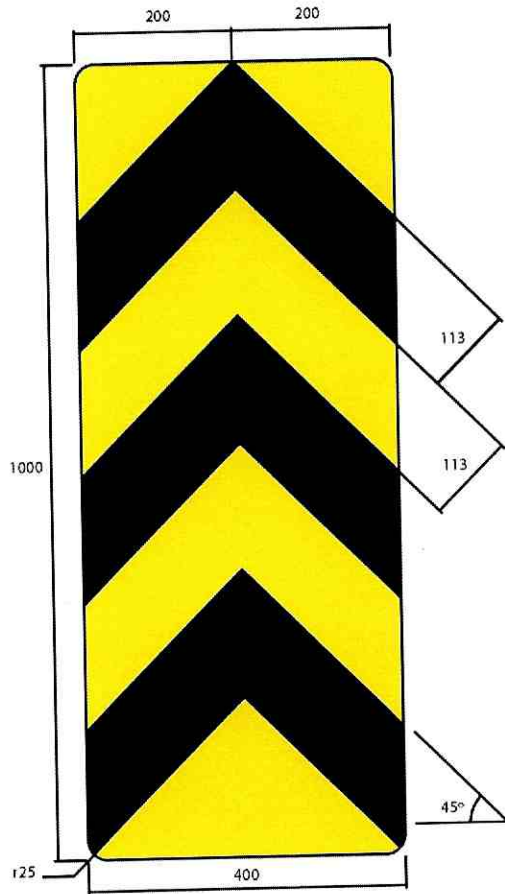

D4

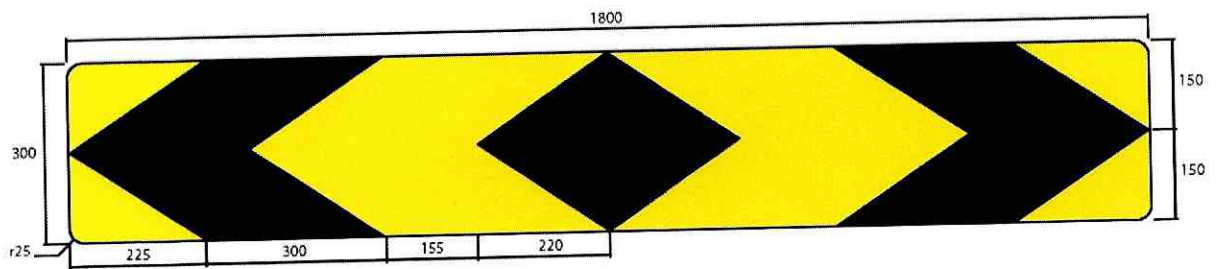

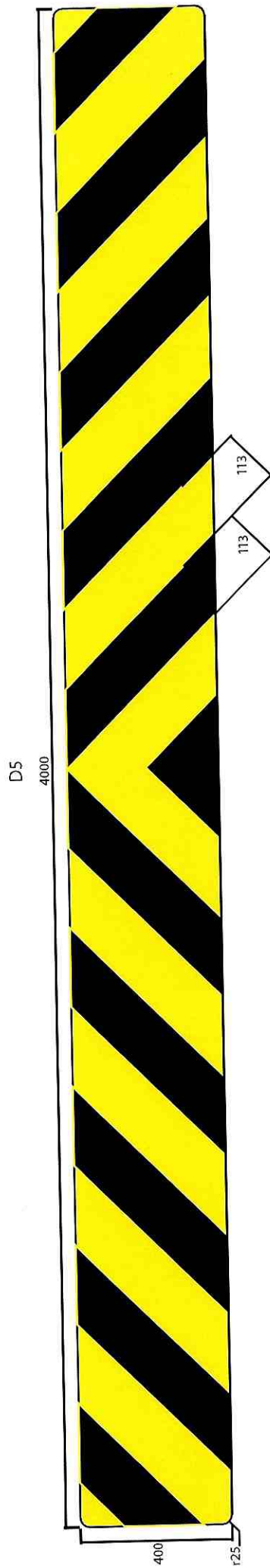

	a	b	c	d	a1	b1	c1	d1	e1	f1	g1	r
D5 (I o D) A	600	750	20	13	112	50	140DA	231	62	100	225	50

D6 I

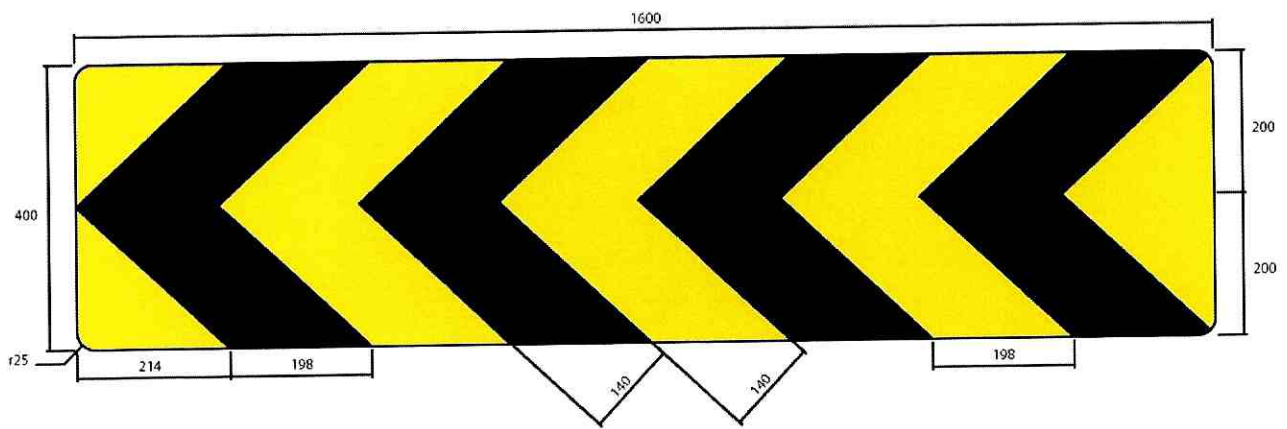

D6 D

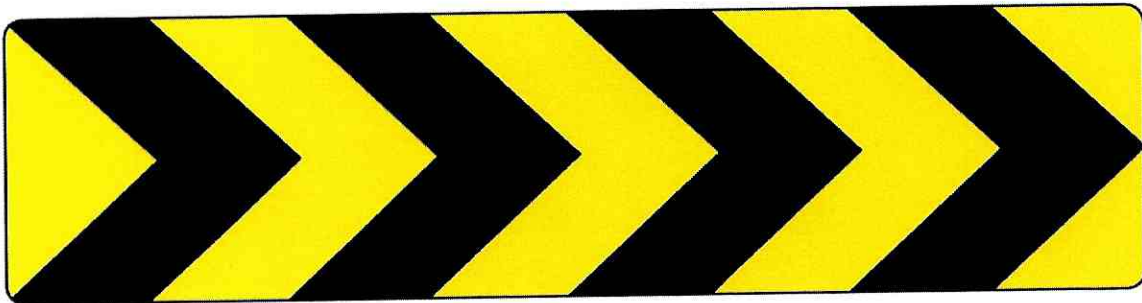

D7 D1

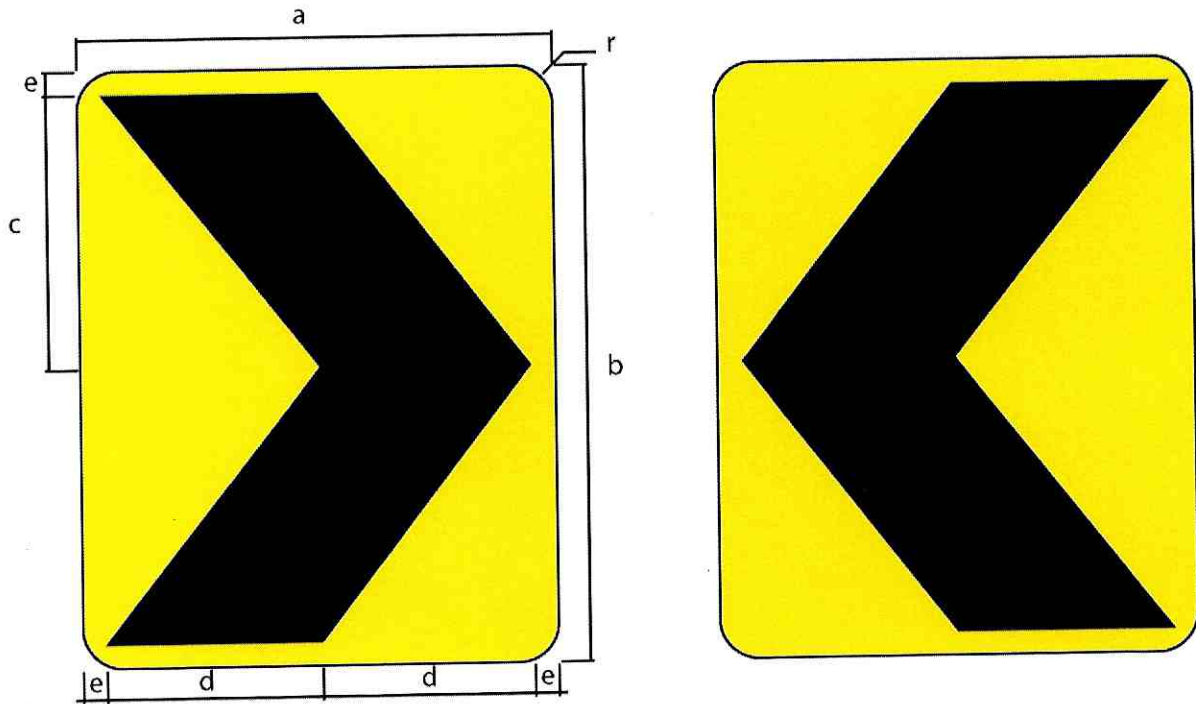

	D7 (I,D) A	D7 (I,D) B	D7 (I,D) C
b	750	900	1200
a	600	750	900
c	320	414	557
d	270	339	407
e	30	36	99
r	50	60	72

600x750

Remache POP

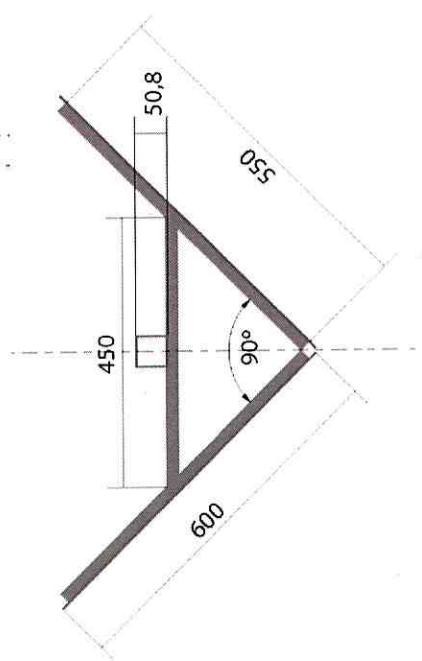
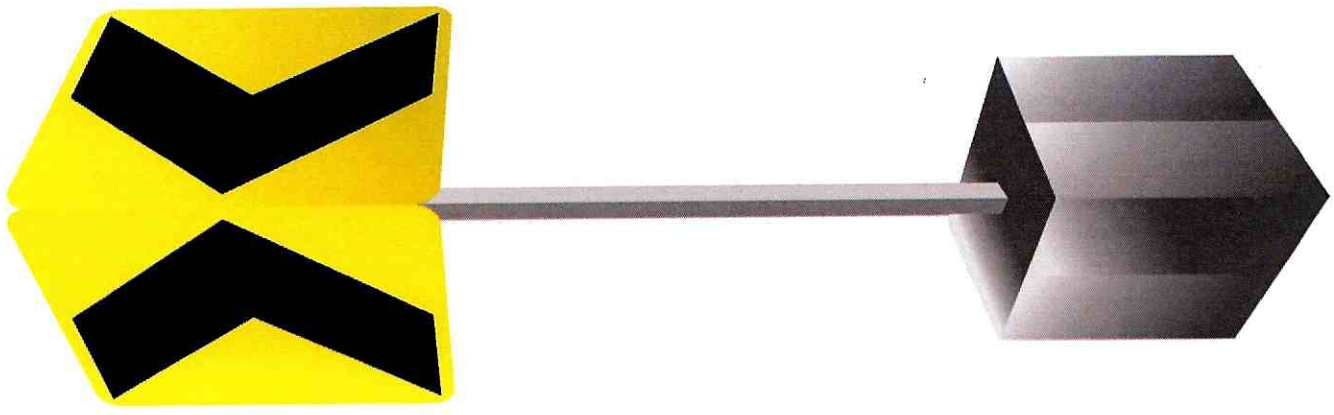
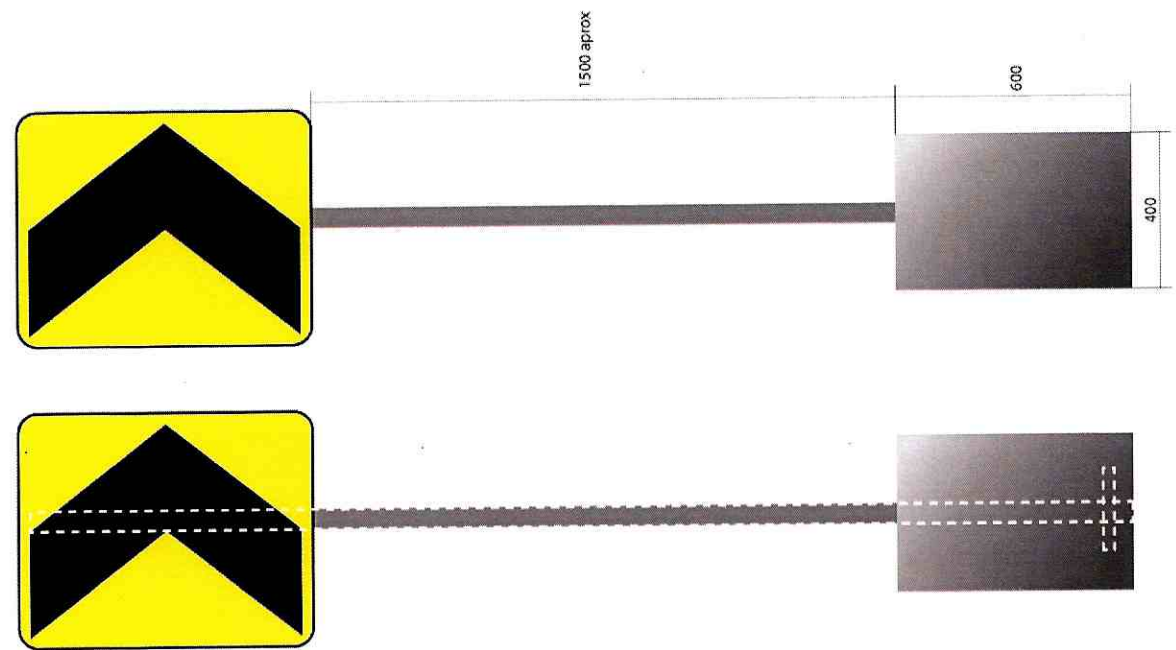
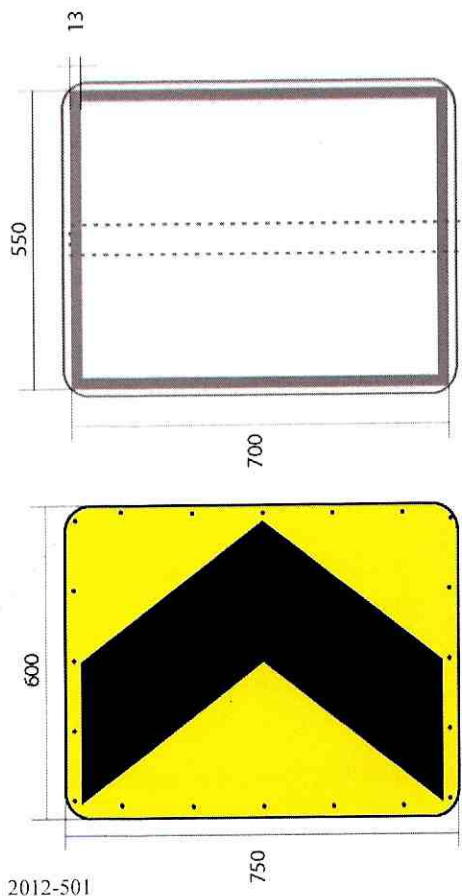

Marco para lámina: Tubo cuadrado de hierro galvanizado de 13mm 1,5mm de espesor sujeto a lámina mediante remache POP

Poste: Tubo cuadrado de 50mm de lado de 2mm de espesor

Plinto: Hormigón de 180kg/cm² Medidas: 40x40x60cm

7.4 Señalización temporal para trabajos en la vía y propósitos especiales. La forma, color y mensaje deben cumplir con las indicadas en cada señal.



T1 - 1
HOMBRES TRABAJANDO

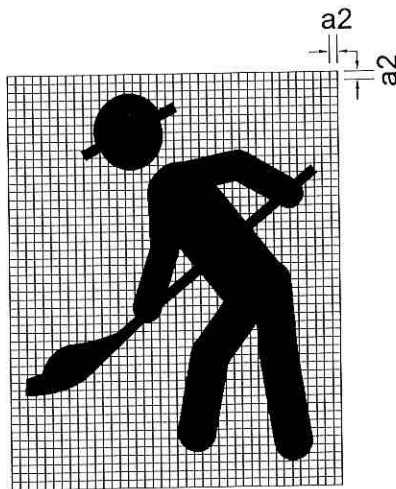
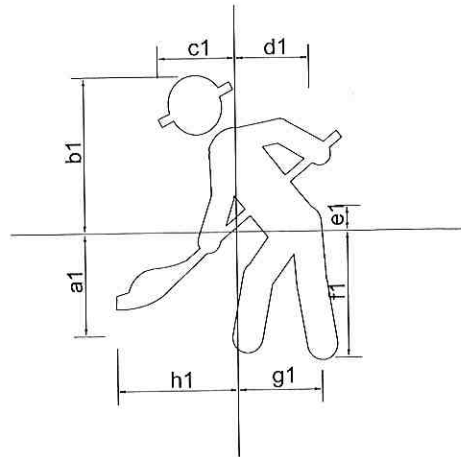
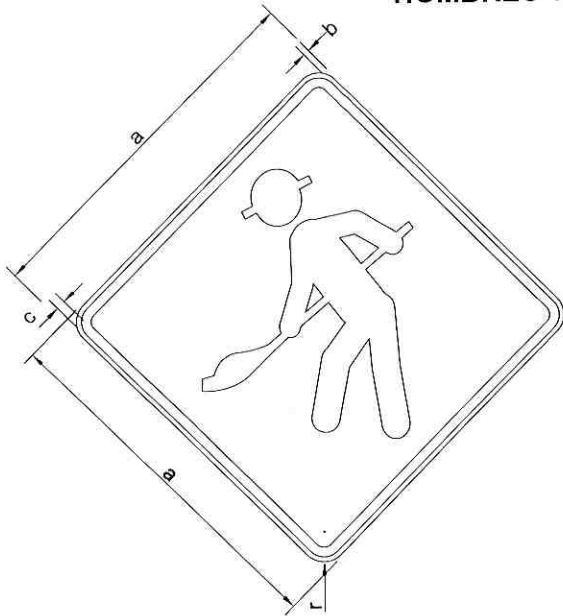

*Cuadrícula

	T1-1 A	T1-1 B	T1-1 C
a	600	750	900
b	8	10	12
c	16	20	24
a1	162	202	242
b1	243	304	364
c1	121	152	182
d1	115	144	172
e1	39	49	58
f1	200	250	300
g1	130	163	196
h1	189	236	283
r	50	50	60
a2	10	13	15



T1 - 2
HOMBRES CON PALETA

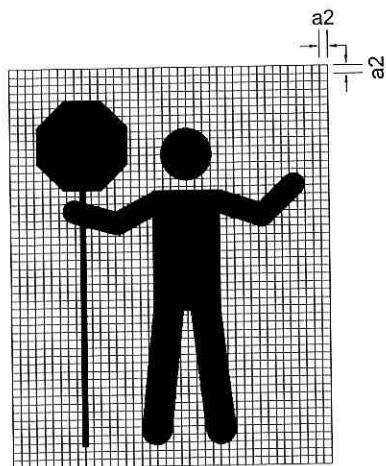
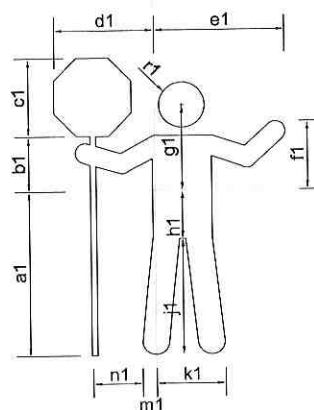
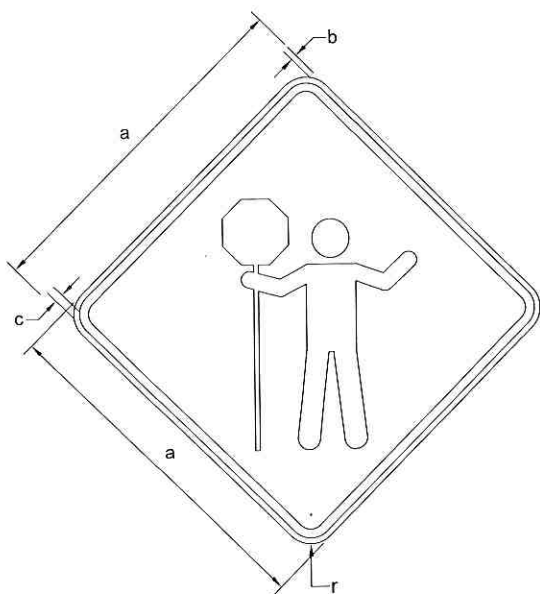

*Cuadrícula

	T1-2 A	T1-2 B	T1-2 C
a	600	750	900
b	8	10	12
c	16	20	24
a1	240	300	360
b1	80	100	120
c1	114	143	172
d1	146	183	220
e1	190	238	285
f1	100	125	150
g1	169	212	254
h1	71	88	105
j1	130	163	195
k1	101	126	151
m1	21	26	31
n1	72	90	108
r	50	50	60
r1	33	41	49
a2	10	13	15



T1 - 3
MAQUINARIA EN LA VÍA

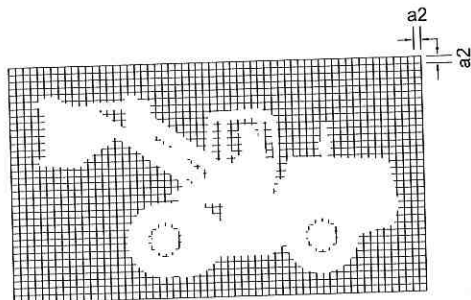
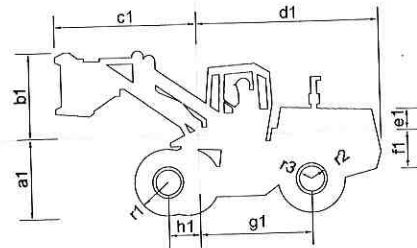
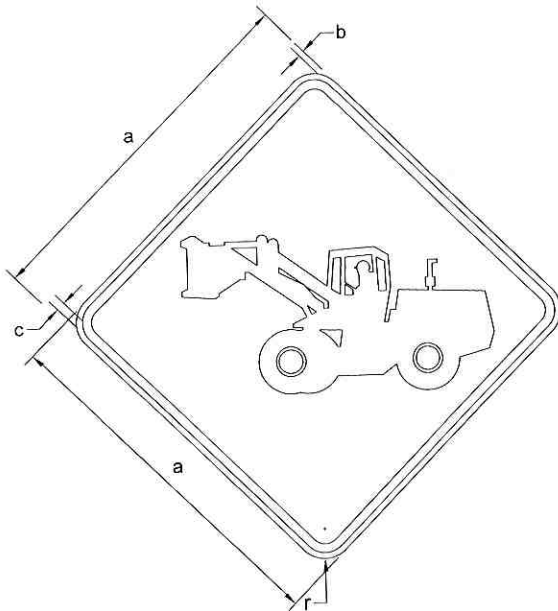

*Cuadrícula

	T1-3 A	T1-3 B	T1-3 C
a	600	750	900
b	8	10	12
c	16	20	24
a1	128	160	192
b1	139	173	208
c1	229	286	343
d1	292	366	439
e1	35	43	52
f1	61	77	92
g1	180	225	270
h1	50	63	75
r	50	50	60
r1	54	67	81
r2	25	31	38
r3	20	25	30
a2	10	13	15



T1 - 4a
ADELANTE TRABAJOS EN LA VÍA

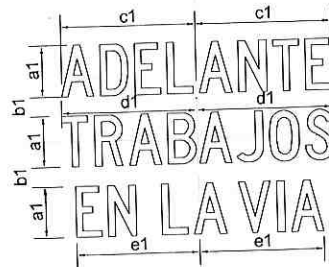
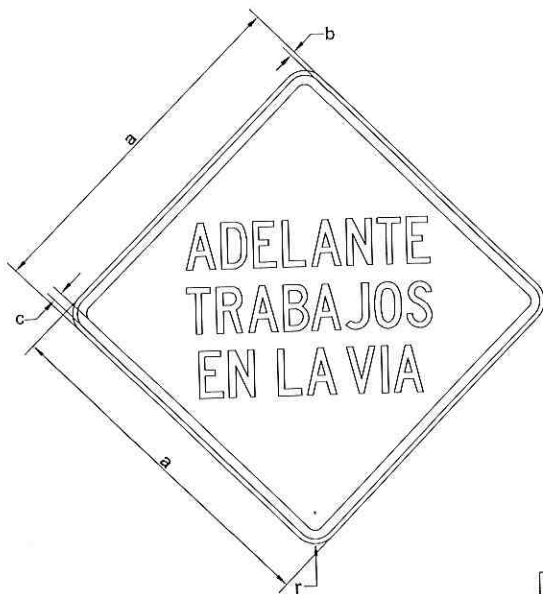

	T1-4a A	T1-4a B
a	600	750
b	8	10
c	16	20
a1	80CA	100CA
b1	30	38
c1	209	262
d1	210	263
e1	192	240
r	50	50



T1 - 5a
ADELANTE TRABAJOS EN PUENTE



	T1-5a A	T1-5a B
a	600	750
b	8	10
c	16	20
a1	80CA	100CA
b1	30	38
c1	209	262
d1	210	263
e1	218	272
r	50	50



T1 - 4b
ADELANTE TRABAJOS
EN LA VÍA

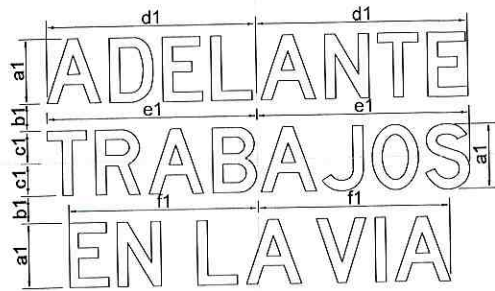

	T1-4b A
a	900
b	1500
c	25
d	15
a1	180DA
b1	75
c1	90
d1	581
e1	582
f1	526
r	60



T1 - 5b
ADELANTE TRABAJOS
EN PUENTE



	T1-5b A
a	900
b	1500
c	25
d	15
a1	180DA
b1	75
c1	90
d1	581
e1	582
f1	588
r	60



T1 - 6
 PRÓXIMOS km
 TRABAJOS EN LA VÍA

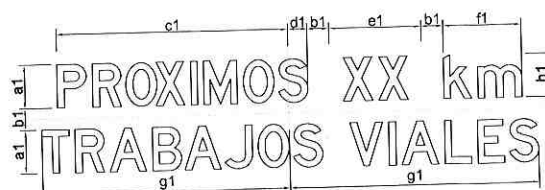

	a	b	c	d	a1	b1	c1	d1	e1	f1	g1	h1	r
T1-6 A	600	2000	25	15	150DA	75	800	67	316	267	855	150Lm	50



T2 - 1a
VIA CERRADA

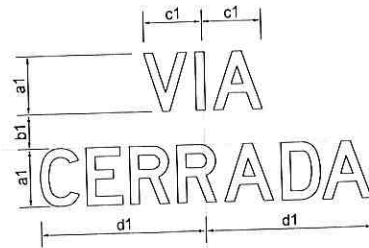
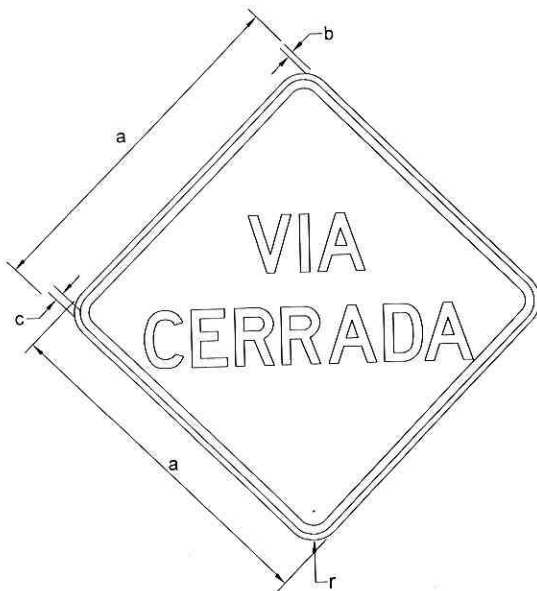

	T2-1a A	T2-1a B
a	600	750
b	8	10
c	16	20
a1	100DA	125CA
b1	60	75
c1	101	127
d1	286	357
r	50	50



T2 - 1b
VIA CERRADA

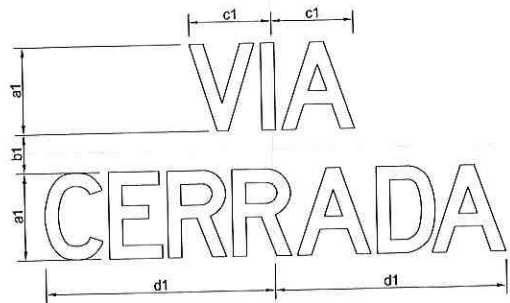

	T2-1b A
a	750
b	1200
c	20
d	13
a1	200Da
b1	90
c1	189
d1	528
r	50



T2 - 2D
CARRIL DER. CERRADO

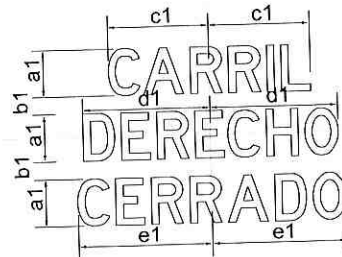
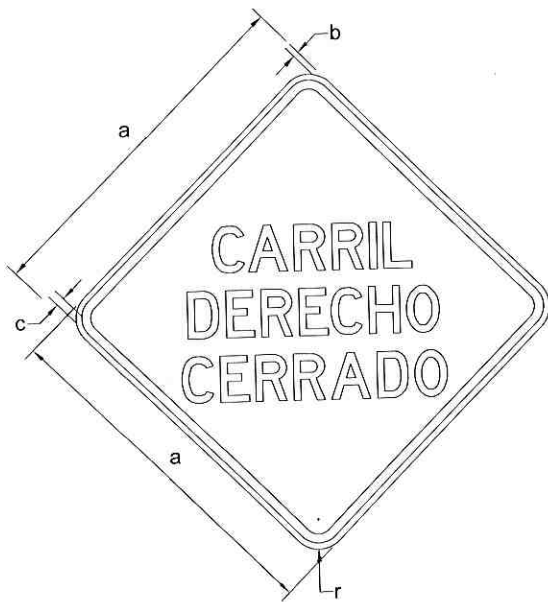

	T2-2D A	T2-2D B	T2-2D C
a	600	750	900
b	8	10	12
c	16	20	24
a1	80DA	100CA	120CA
b1	30	38	45
c1	171	213	256
d1	216	270	324
e1	228	284	341
r	50	50	60



T2 - 21
CARRIL IZQ. CERRADO

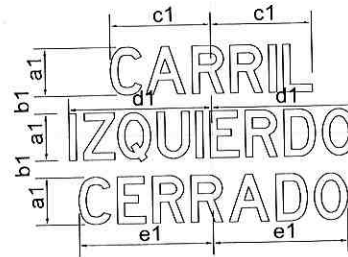
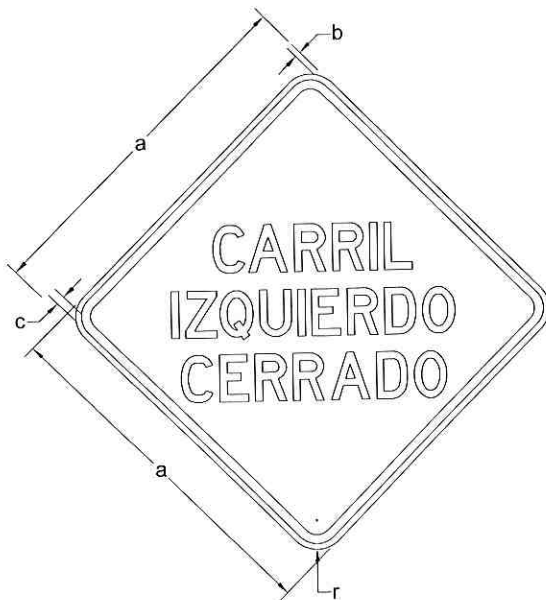

	T2-21 A	T2-21 B	T2-21 C
a	600	750	900
b	8	10	12
c	16	20	24
a1	80DA	100CA	120CA
b1	30	38	45
c1	171	213	256
d1	243	304	364
e1	228	284	341
r	50	50	60



T2 - 3a
ESTADO DE CARRIL

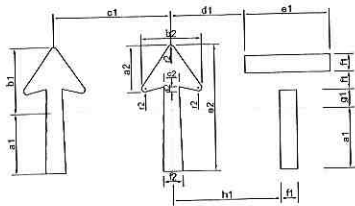
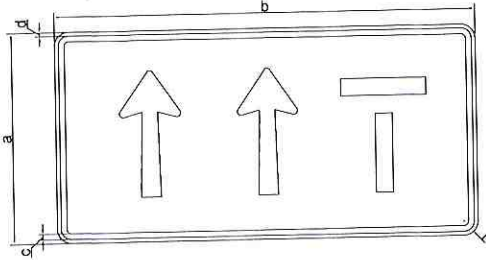

T2-3a A	a	b	c	d	a1	b1	c1	d1	e1	f1	g1	h1
	900	1800	25	15	260	280	500	315	370	75	80	463

a2	b2	c2	d2	e2	f2	r	r2
197	258	65	22	540	82	60	15



T2 - 3b
ESTADO DE CARRIL

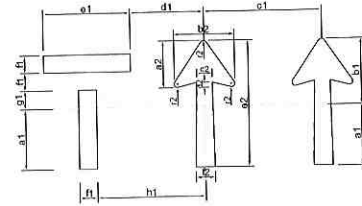
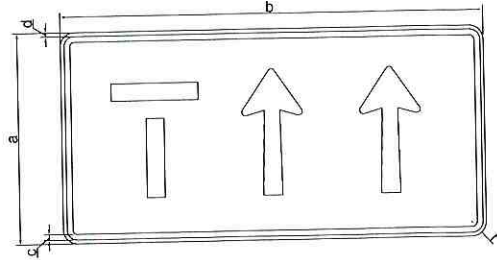

T2-3b B	a	b	c	d	a1	b1	c1	d1	e1	f1	g1	h1
	900	1800	25	15	260	280	500	315	370	75	80	463

a2	b2	c2	d2	e2	f2	r	r2
197	258	65	22	540	82	60	15



T2 - 3c
ESTADO DE CARRIL

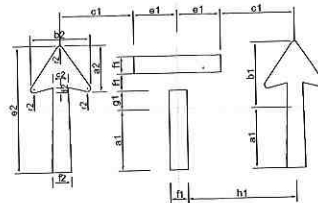
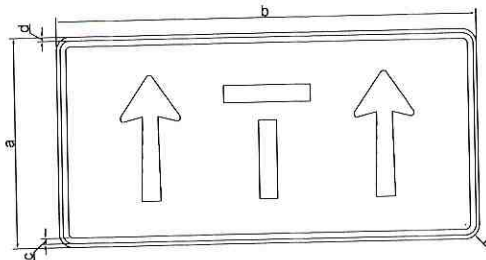

T2-3c C	a	b	c	d	a1	b1	c1	e1	f1	g1	h1
	900	1800	25	15	260	280	315	185	75	80	463

a2	b2	c2	d2	e2	f2	r	r2
197	258	65	22	540	82	60	15



T3 - 1a
DESVÍO

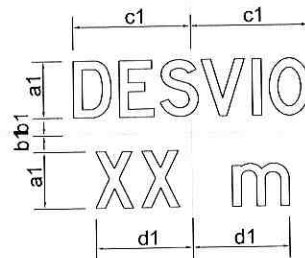

SERIE - D

100 500

100

150

200

250

300

500

	T3-1a A	T3-1a B
a	600	750
b	8	10
c	16	20
a1	100DA	125DA
b1	30	38
c1	208	260
d1	171	213
r	50	50



T3 - 2a
TERMINA DESVÍO

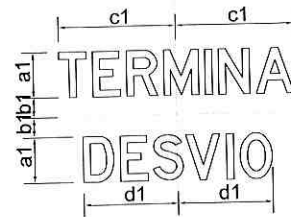

	T3-2a A	T3-2a B
a	600	750
b	8	10
c	16	20
a1	80DA	100DA
b1	35	44
c1	207	259
d1	166	208
r	50	50



T3 - 1b
DESVÍO

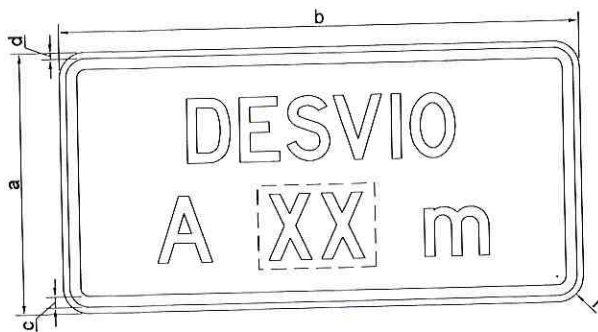
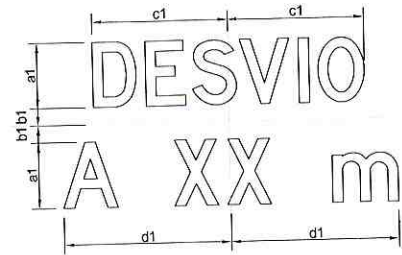

T3-1b A	
a	600
b	1200
c	25
d	15
a1	150DA
b1	40
c1	312
d1	384
r	60



T3 - 2b
TERMINA DESVÍO

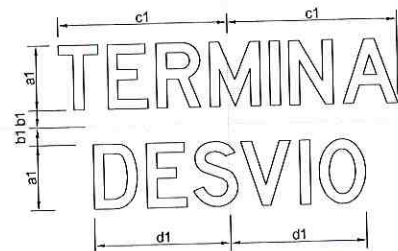

T3-2b A	
a	600
b	1200
c	25
d	15
a1	150DA
b1	40
c1	389
d1	312
r	60



T3 - 3aI
DESVÍO A LA IZQ.



T3 - 3aD
DESVÍO A LA DER.

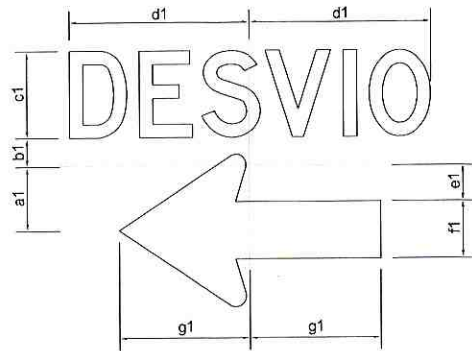

	a	b	c	d	a1	b1	c1	d1	e1	f1	g1	r
T3-3a(I,D) A	600	750	20	13	112	50	150DA	312	62	100	225	50



T3 - 3bI
DESVÍO A LA IZQ.



T3 - 3bD
DESVÍO A LA DER.

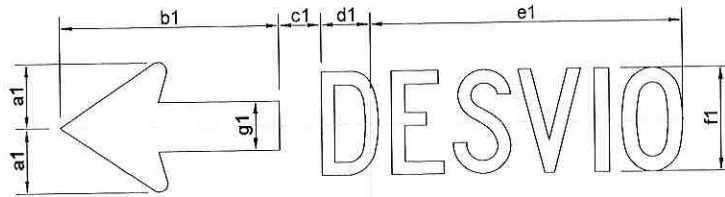
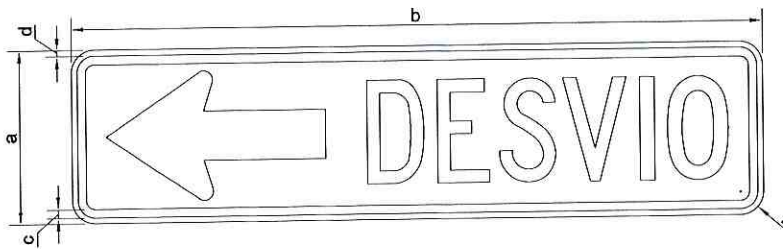

	a	b	c	d	a1	b1	c1	d1	e1	f1	g1	r
T3-3b(I,D) A	300	1200	15	10	112	382	72	85	540	180CA	85	50
T3-3b(I,D) B	450	1800	25	15	165	550	132	128	810	270CA	125	60



**T4-1
ASFALTO FRESCO**

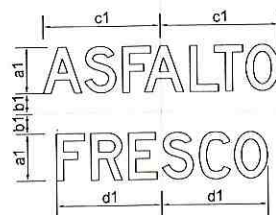

	T4-1 A	T4-1 B
a	750	900
b	8	10
c	16	20
a1	100DA	120DA
b1	44	53
c1	254	305
d1	227	273
r	50	60



T4 - 2
VÍA DE GRANILLO



	T4-2 A	T4-2 B
a	750	900
b	8	10
c	16	20
a1	100DA	120DA
b1	44	53
c1	216	260
d1	293	351
r	50	60



T4 - 3
AGUA EN LA VÍA

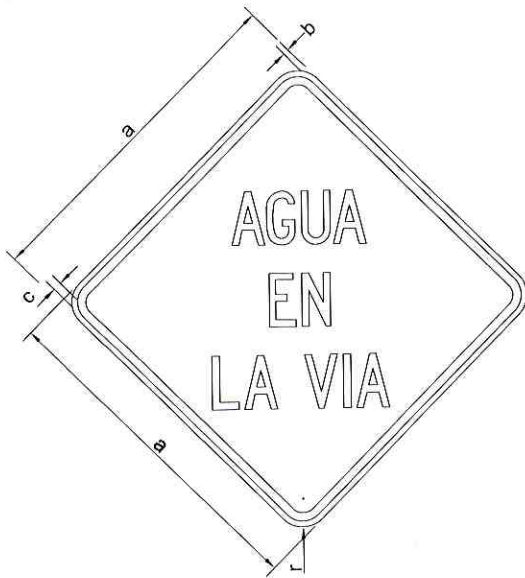

	T4-3 A	T4-3 B
a	750	900
b	8	10
c	16	20
a1	120CA	145CA
b1	63	76
c1	151	183
d1	69	84
e1	200	242
r	50	60



T5 - 1
FIN DE TRABAJOS

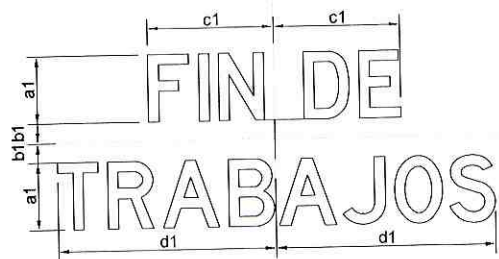

	T5-1 A	T5-1 B
a	600	900
b	1200	1800
c	25	30
d	15	20
a1	140DA	210DA
b1	40	60
c1	261	391
d1	453	679
r	60	70



**T5 - 2
FIN DE TRABAJOS**

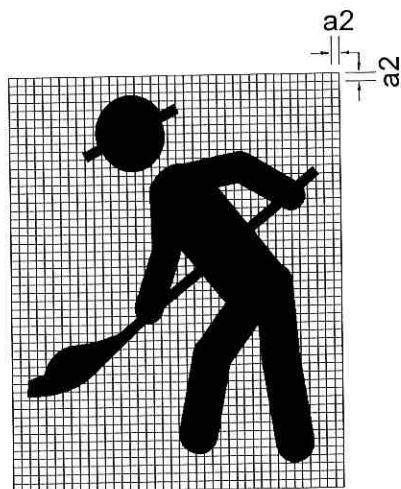
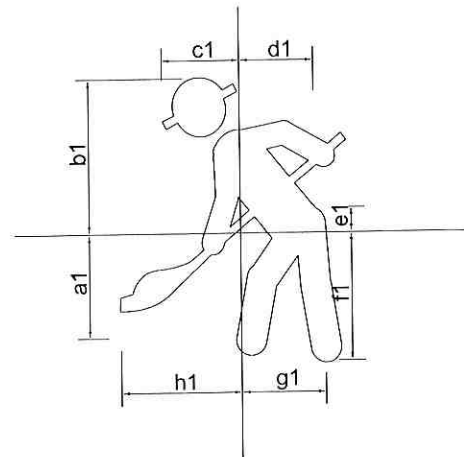
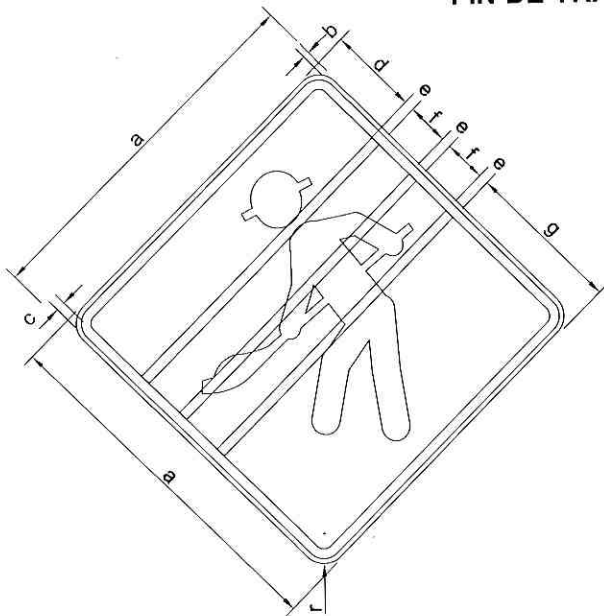

***Cuadrícula**

	T5-2 A	T5-2 B	T5-2 C
a	600	750	900
b	8	10	12
c	16	20	24
d	150	188	225
e	17	21	26
f	70	88	105
g	259	324	389
a1	162	202	242
b1	243	304	364
c1	121	152	182
d1	115	144	172
e1	39	49	58
f1	200	250	300
g1	130	163	196
h1	189	236	283
r	50	50	60
a2	10	13	15

7.5 Señalización para zonas escolares. La forma, color y mensaje deben cumplir con las indicadas en cada señal.

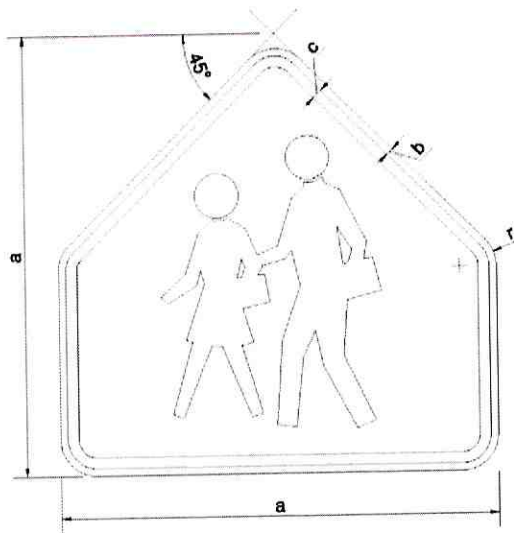

E1 - 1
ADVERTENCIA ZONA ESCOLAR

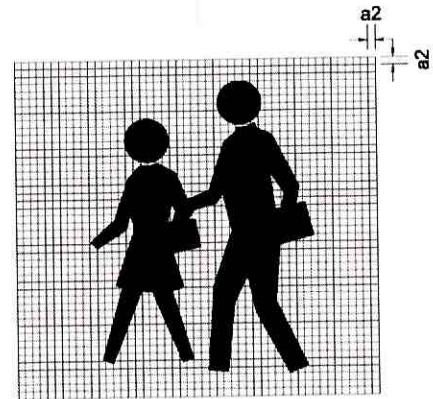
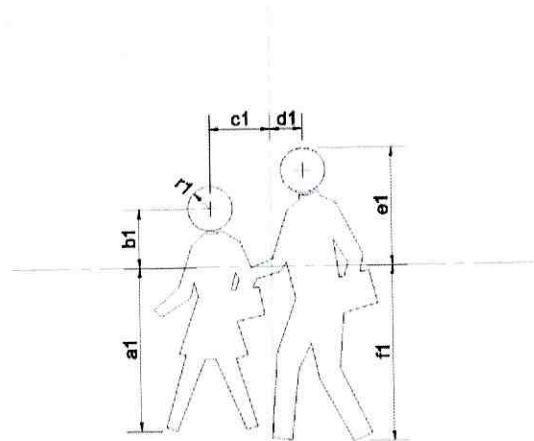

*Cuadrícula

	E1-1 A	E1-1 B	E1-1 C
a	600	750	900
b	10	13	15
c	15	20	25
a1	223	279	335
b1	79	99	119
c1	82	103	124
d1	44	55	66
e1	160	201	241
f1	240	300	360
r	50	50	60
r1	30	38	45
a2	10	13	15

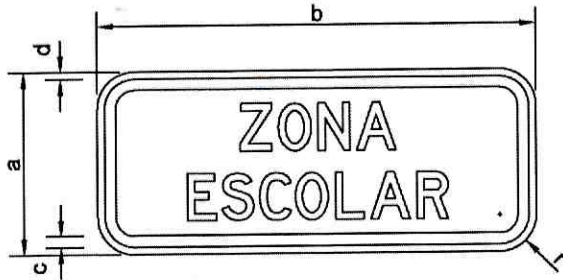

E 2 - 5
ZONA ESCOLAR

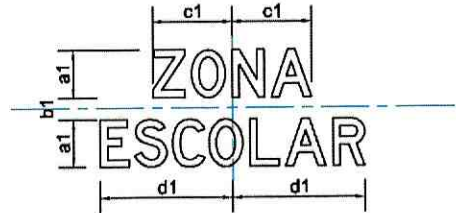

	E2-5 A	E2-5 B	E2-5 C
a	600	900	1200
b	250	375	500
c	15	25	30
d	10	15	20
a1	65DA	95DA	130DA
b1	30	44	60
c1	108	157	215
d1	179	262	359
r	50	60	70

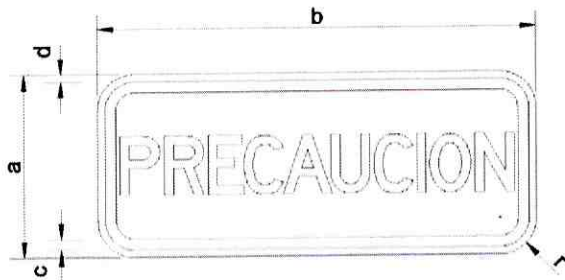

E 2 - 6
PRECAUCIÓN

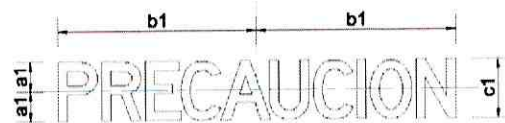

	E2-6 A	E2-6 B	E2-6 C
a	600	900	1200
b	250	375	500
c	15	25	30
d	10	15	20
a1	40	60	80
b1	270	405	539
c1	80Da	120Da	160Da
r	50	60	70

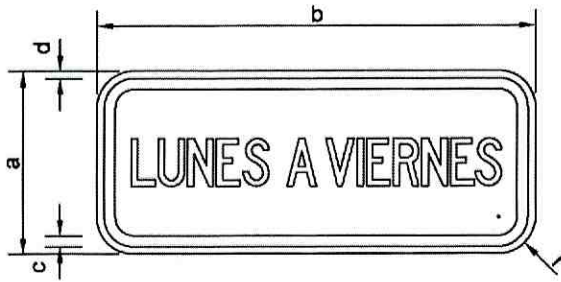

E 2 - 3
HORARIOS

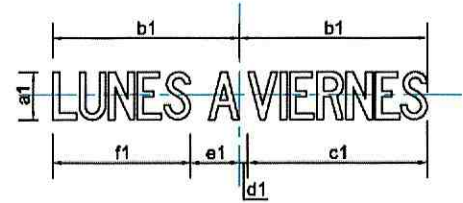

	E2-3 A	E2-3 B	E2-3 C
a	600	900	1200
b	250	375	500
c	15	25	30
d	10	15	20
a1	65Ca	100Ca	130Ca
b1	254	391	508
c1	242	373	485
d1	12	18	23
e1	66	102	132
f1	188	289	375
r	50	60	70

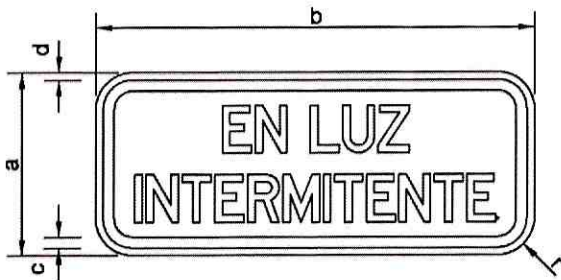

E 2 - 4
EN LUZ INTERMITENTE

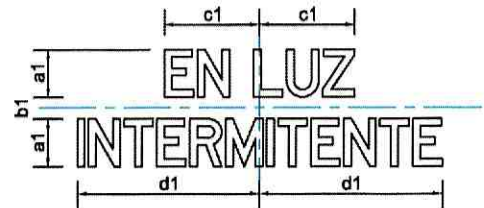

	E2-4 A	E2-4 B	E2-4 C
a	600	900	1200
b	250	375	500
c	15	25	30
d	10	15	20
a1	65DA	100DA	130DA
b1	30	46	60
c1	129	198	258
d1	248	381	495
r	50	60	70

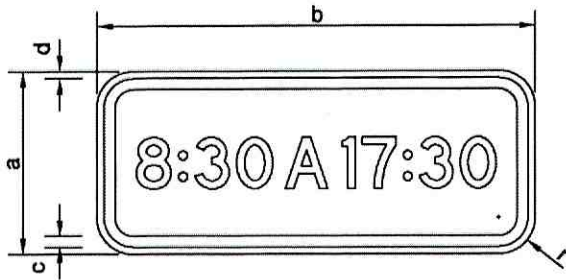

E 2 - 1
HORARIOS

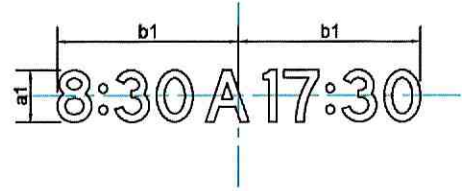

	E2-1 A	E2-1 B	E2-1 C
a	600	900	1200
b	250	375	500
c	15	25	30
d	10	15	20
a1	70DA	105DA	140DA
b1	247	370	493
r	50	60	70

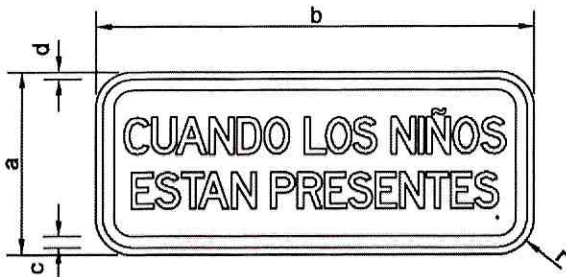

E 2 - 2
CUANDO LOS NIÑOS ESTÁN
PRESENTES



	E2-2 A	E2-2 B	E2-2 C
a	600	900	1200
b	250	500	750
c	15	25	30
d	10	15	20
a1	62	100	140
b1	261	392	523
c1	50Da	75Da	100Da
d1	25	50	80
e1	252	378	503
r	50	60	70

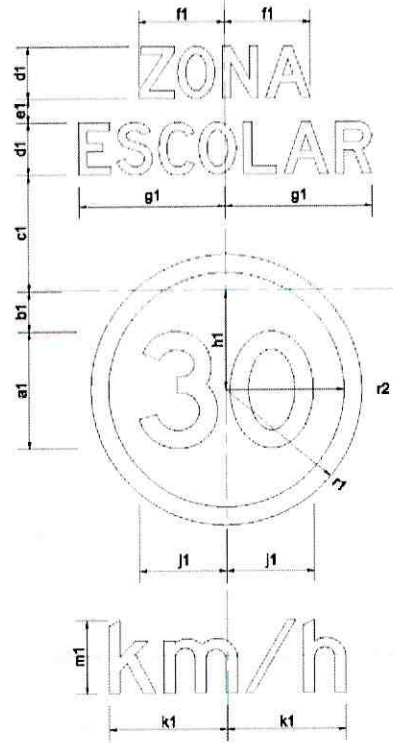
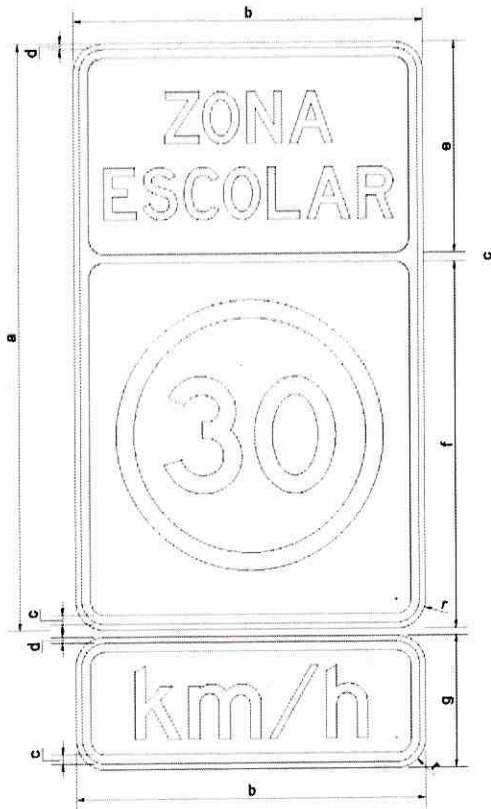

ER1 - 1
VELOCIDAD MÁXIMA



	ER1-1 A	ER1-1 B
a	1000	1500
b	600	900
c	15	25
d	10	15
e	360	539
f	625	936
g	225	338
a1	200DM	300DM
b1	69	113
c1	198	297
d1	90DA	135DA
e1	40	60
f1	146	218
g1	249	373
h1	189	263
j1	148	222
k1	201	301
m1	125Lm	185Lm
r	50	60
r1	230	345
r2	200	300

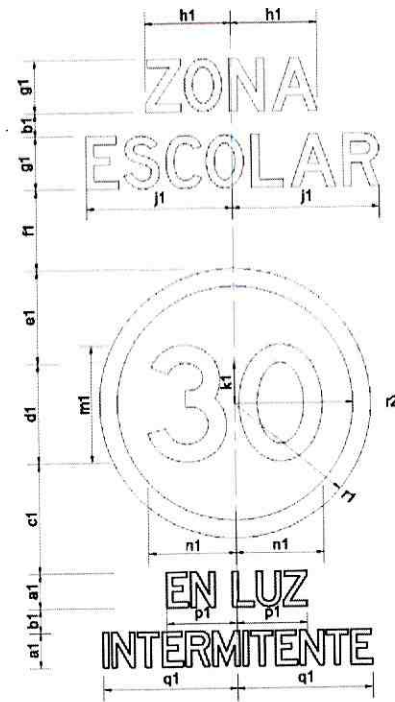
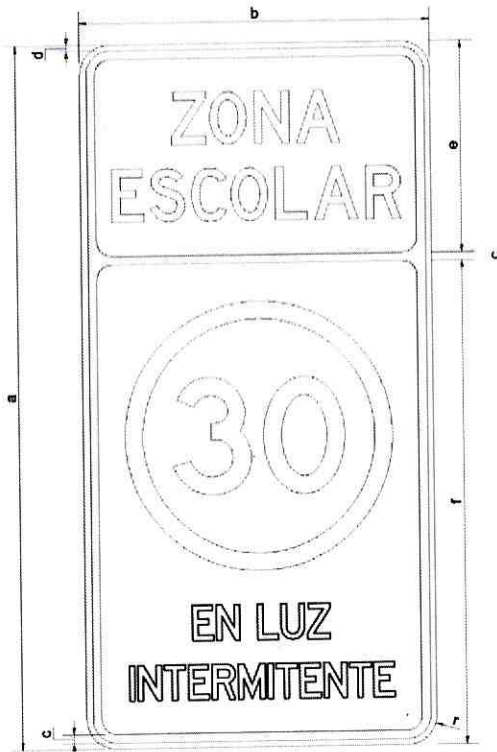

ER1 - 2
VELOCIDAD MÁXIMA



	ER1-2 A	ER1-2 B
a	1200	1800
b	600	900
c	15	25
d	10	15
e	360	539
f	825	1236
a1	60DA	90DA
b1	40	60
c1	188	281
d1	170	255
e1	160	240
f1	138	206
g1	90DA	135DA
h1	146	218
j1	249	373
k1	70	105
m1	200DM	300DM
p1	119	178
q1	228	343
r	50	60
r1	230	345
r2	200	300

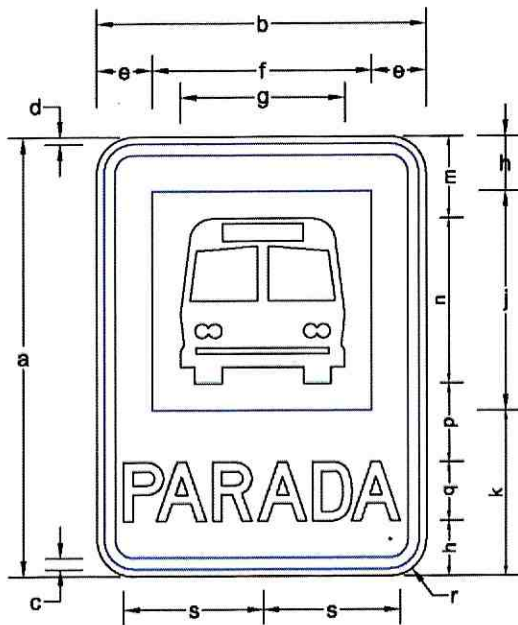

R5-6
PARADA DE BUS

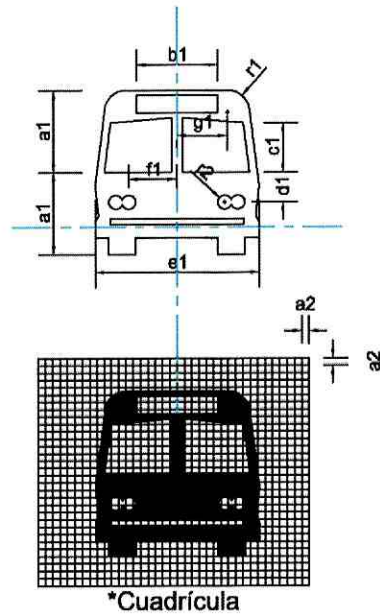

R5-6A	
a	600
b	450
c	15
d	10
e	75
f	300
g	225
h	75
j	300
k	225
m	112
n	225
p	108
q	80DM
s	189
a1	112
b1	111
c1	68
d1	41
e1	225
f1	66
r	50
r1	30
r2	10
a2	10

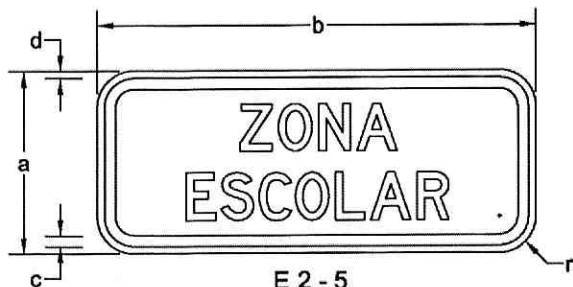

E 2 - 5
ZONA ESCOLAR

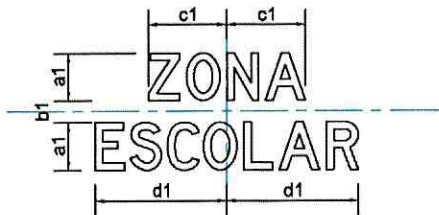

E2-5 A	
a	600
b	250
c	15
d	10
a1	65DA
b1	30
c1	108
d1	179
r	50



ER 2 - 5
PARADA DE BUS EN ZONA
ESCOLAR

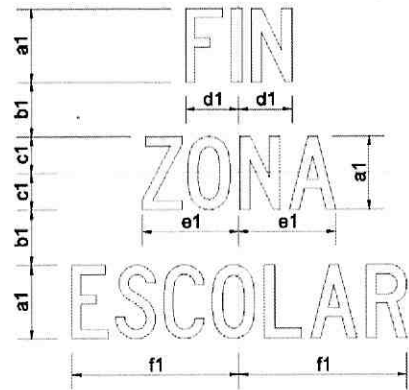

ER3 - 1
FIN DE ZONA ESCOLAR



	ER3-1 A	ER3-1 B
a	750	1200
b	600	900
c	15	25
d	10	15
a1	100CA	160CA
b1	75	120
c1	50	80
d1	72	115
e1	131	210
f1	227	364
r	50	60

7.6 Señales turísticas y de servicios. La forma, color y mensaje deben cumplir con las indicadas en cada señal.

IT1 – ATRACTIVOS NATURALES

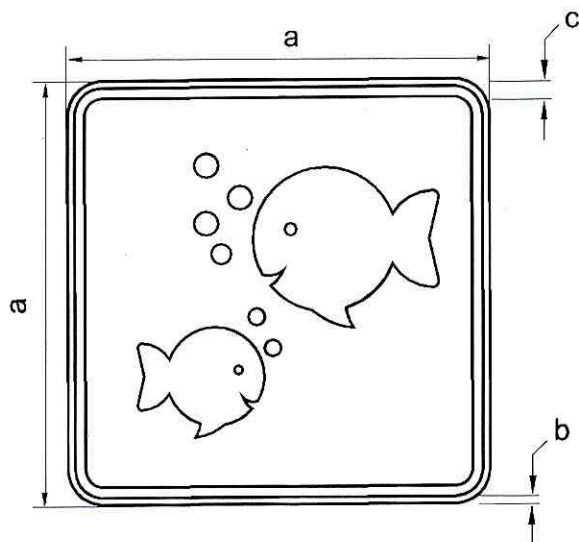

	IT1-1 A	IT1-1 B
a	600	750
b	8	10
c	16	20

IT1-1
Acuario

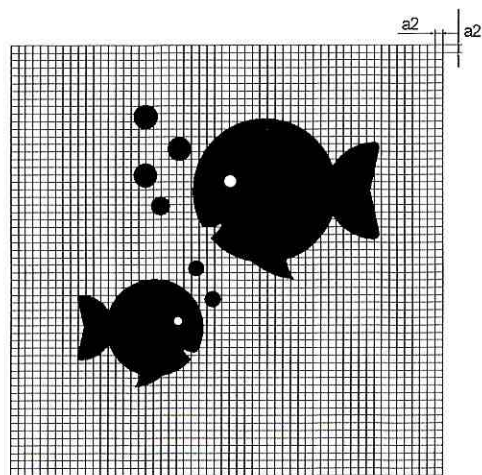
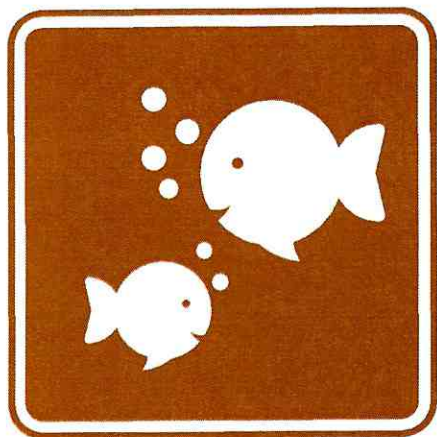

*Cuadrícula

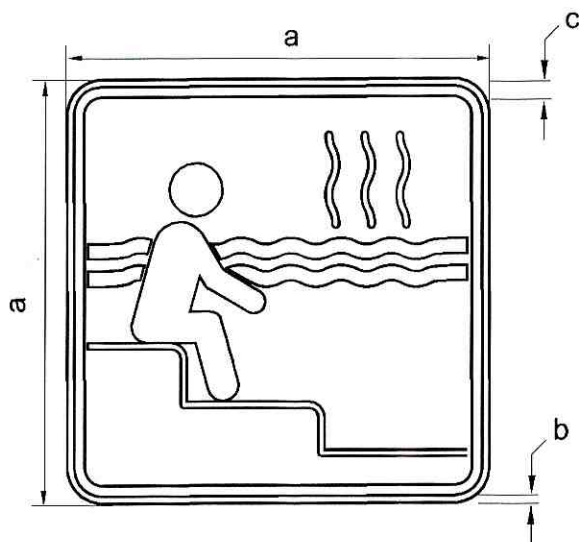

	IT1-2 A	IT1-2 B
a	600	750
b	8	10
c	16	20

IT1-2
Termas

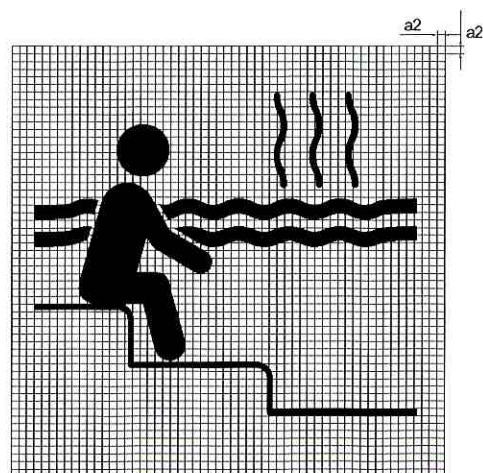

*Cuadrícula

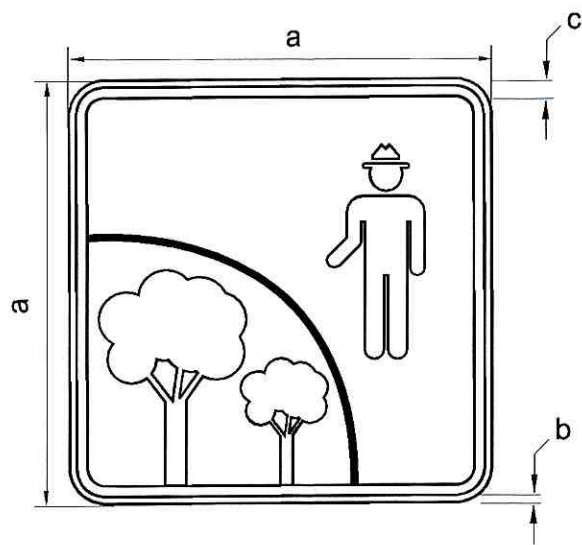

	IT1-3 A	IT1-3 B
a	600	750
b	8	10
c	16	20

IT1-3

Área protegida

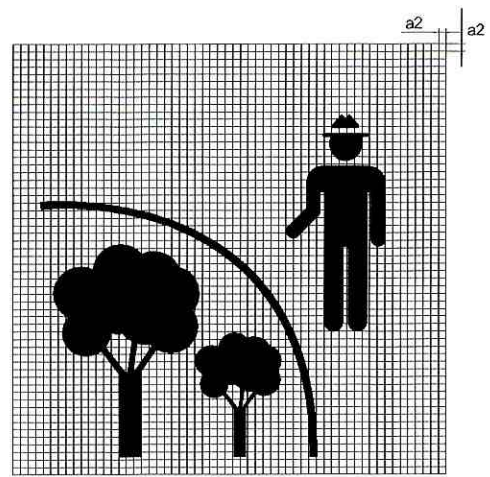

*Cuadrícula

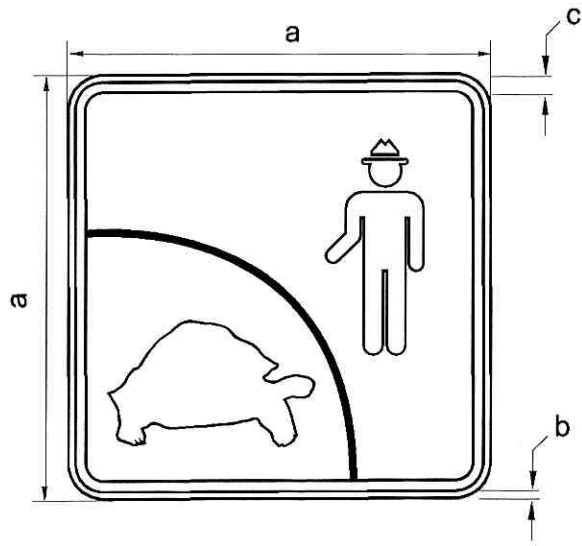

	IT1-3a A	IT1-3a B
a	600	750
b	8	10
c	16	20

IT1-3a
 Área protegida
 Galápagos

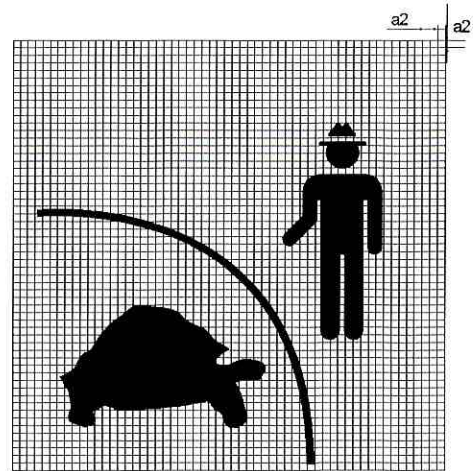
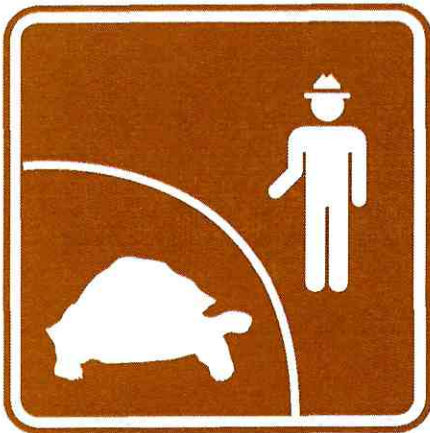

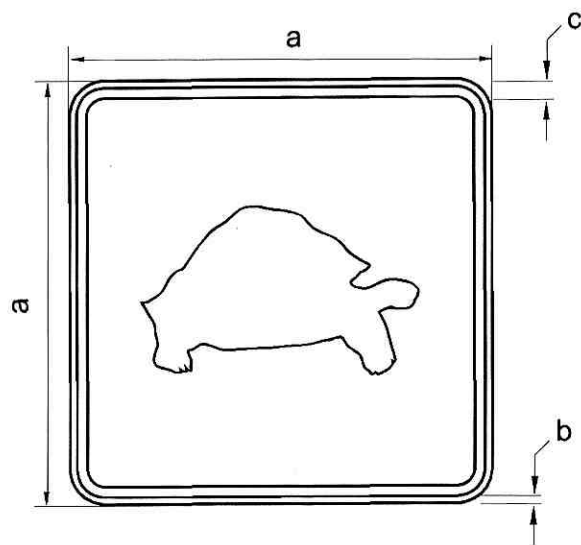

	IT1-3b A	IT1-3b B
a	600	750
b	8	10
c	16	20

IT1-3b
Observación de tortugas

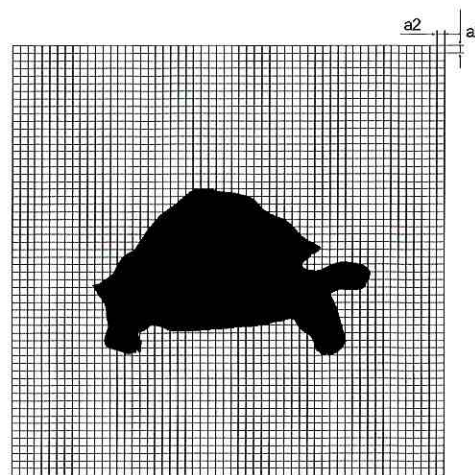
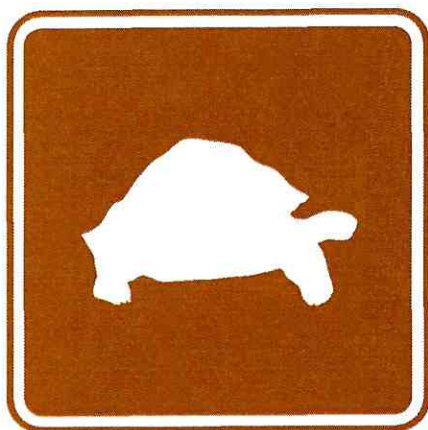

*Cuadrícula

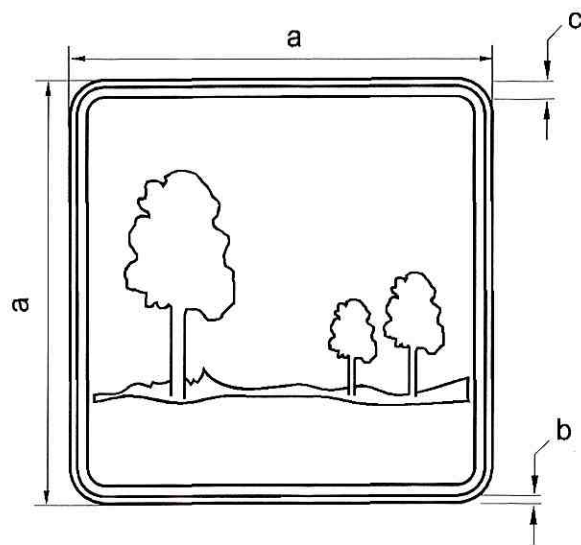

	IT1-4 A	IT1-4 B
a	600	750
b	8	10
c	16	20

IT1-4
Bosque

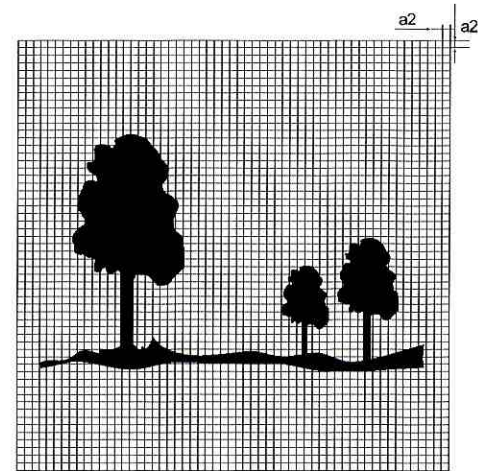

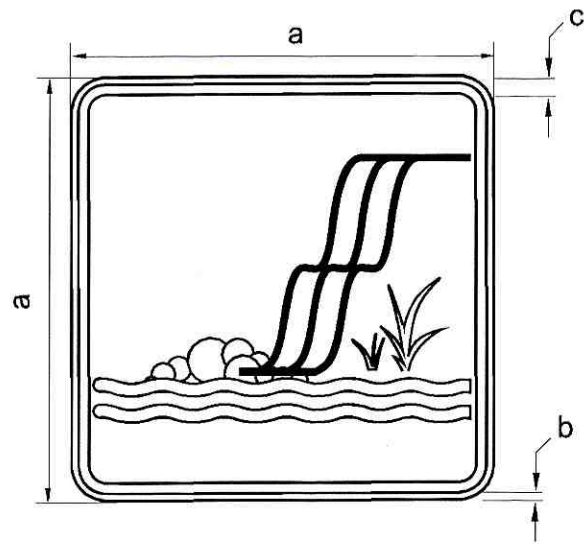

	IT1-5 A	IT1-5 B
a	600	750
b	8	10
c	16	20

IT1-5
Cascada

